



Science and
Technology
Facilities Council

ITRF Project

Mechanical Engineering Design

LhARA Low Energy Line

Clive Hill

30/08/23

1272-pa1-meng-prs-0011 v1.0

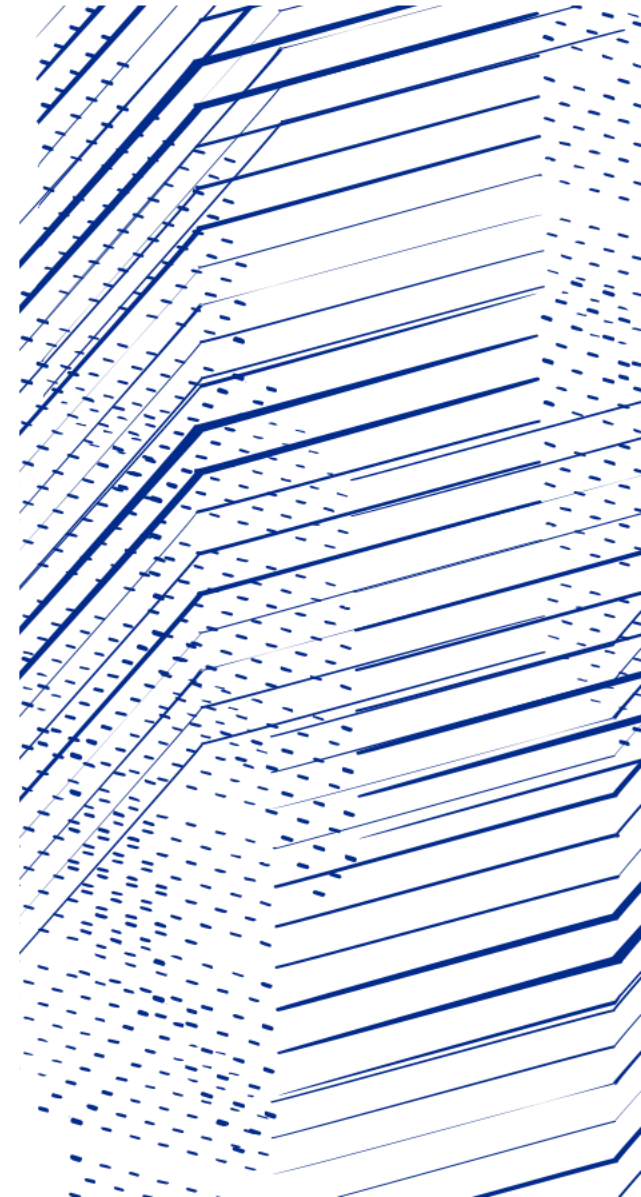

Pumping station and beam profile monitor between Gabor lenses

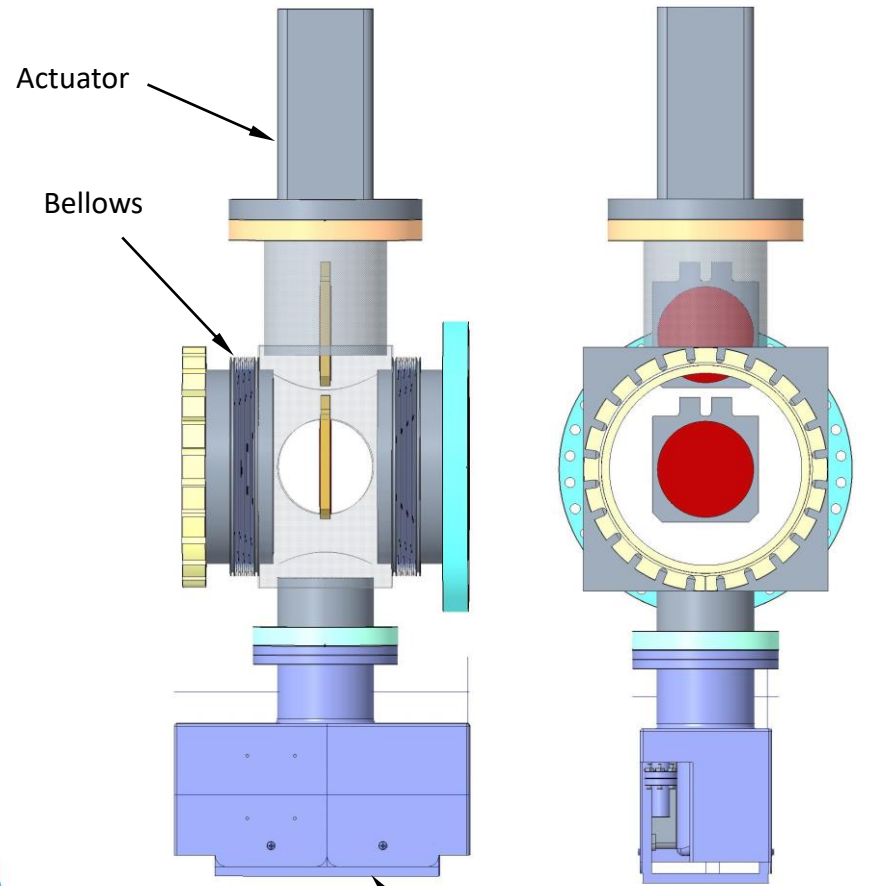
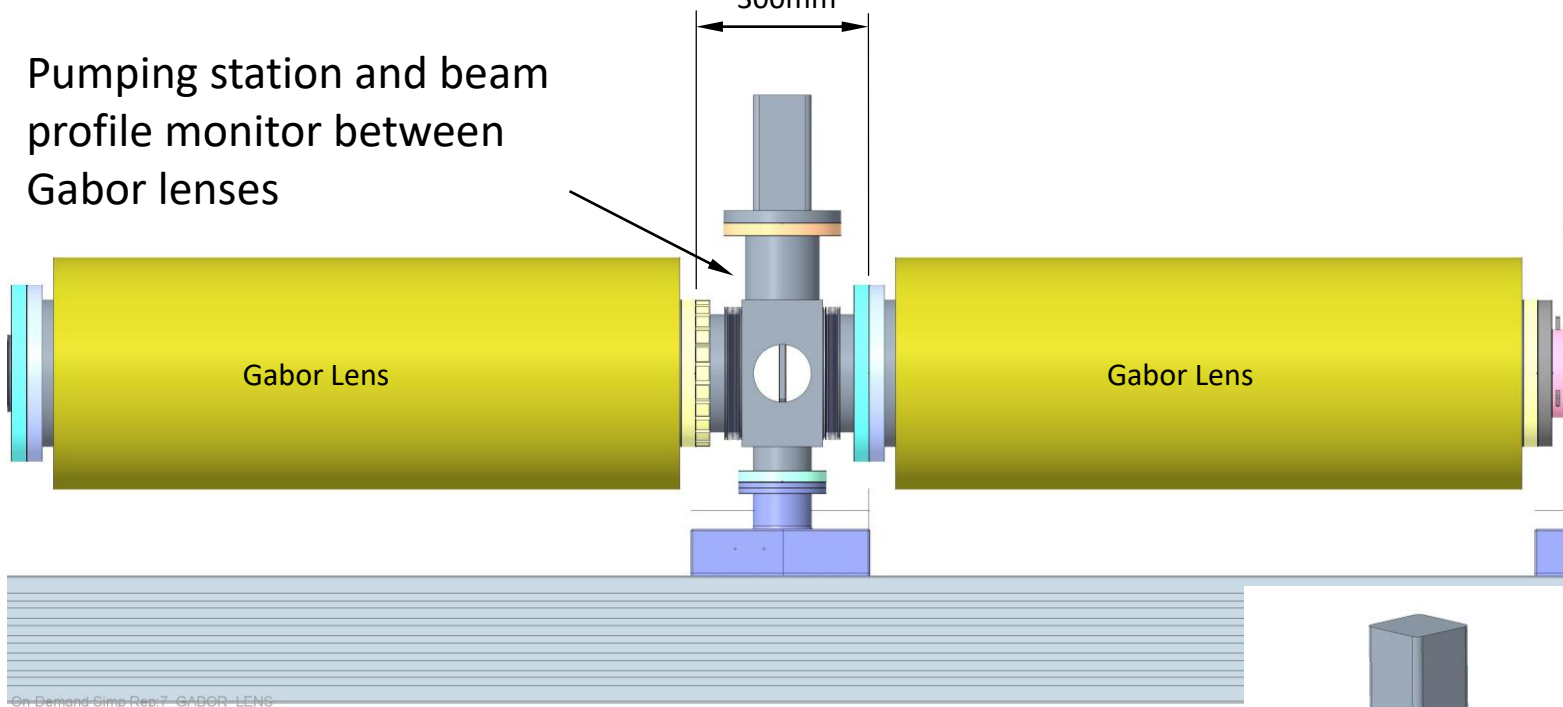

Ion pump

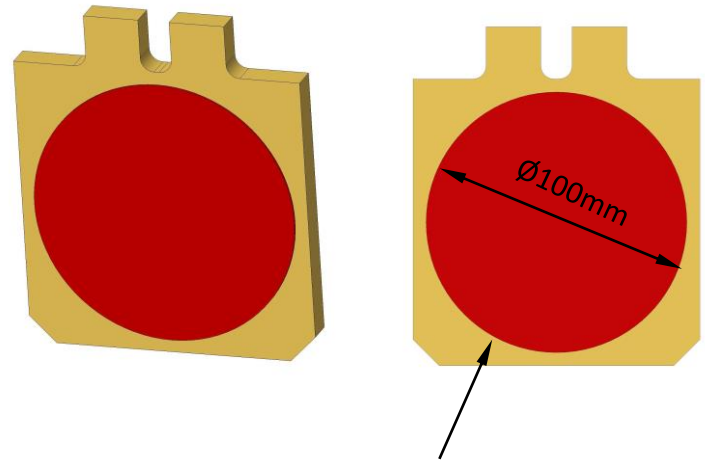

Aperture requirement as specified on spreadsheet v4.5.2

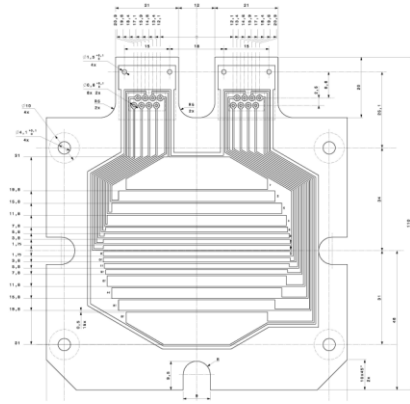

Beam Profile Monitor
Courtesy of IBA

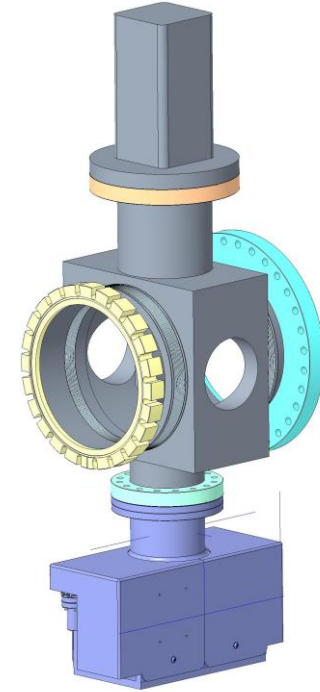

Standard pumping station and beam profile monitor

