



# PoPLaR Beamline

Equipment, set up & simulations

# Limitations

- Must be focused within 1.8m
- Must not be too close to laser
- Must be able to focus energies from 5-15MeV

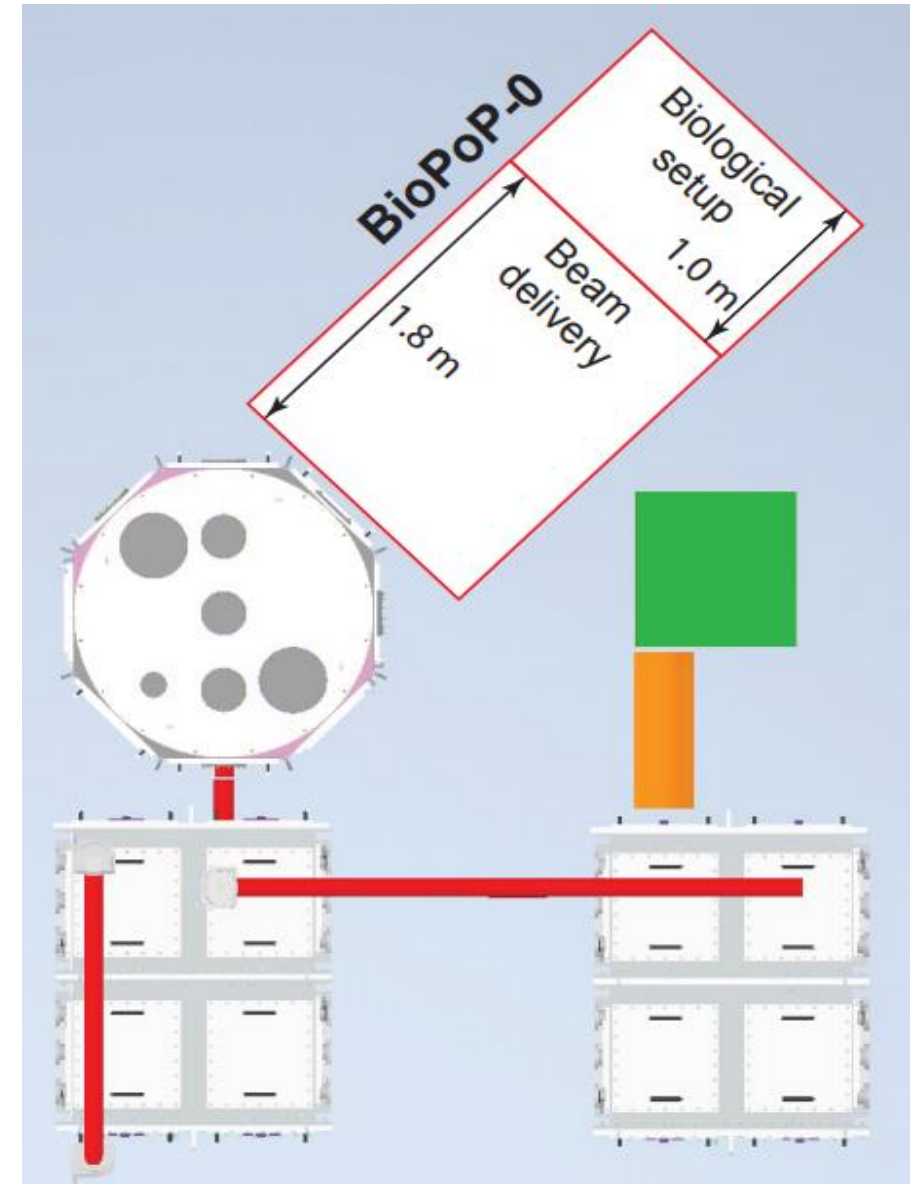

# Beamline set up

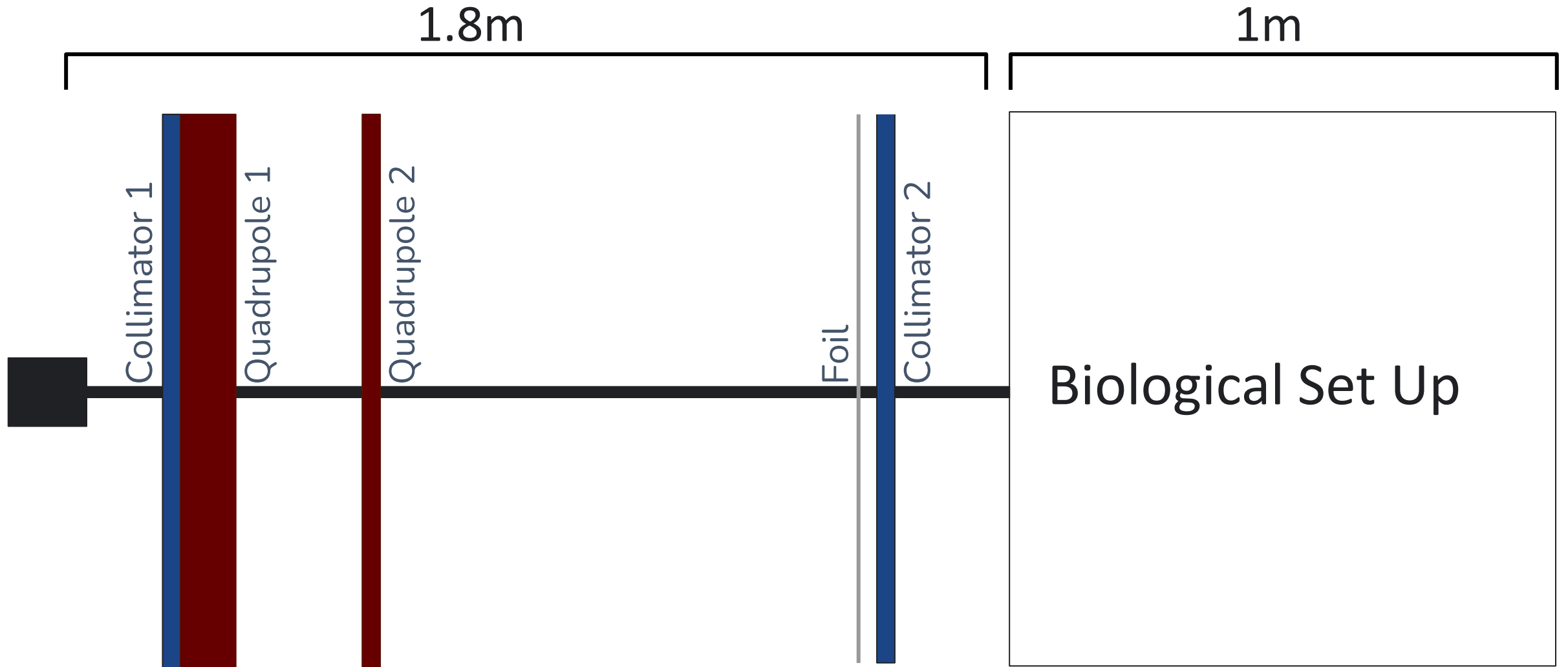

# Quadrupole Design

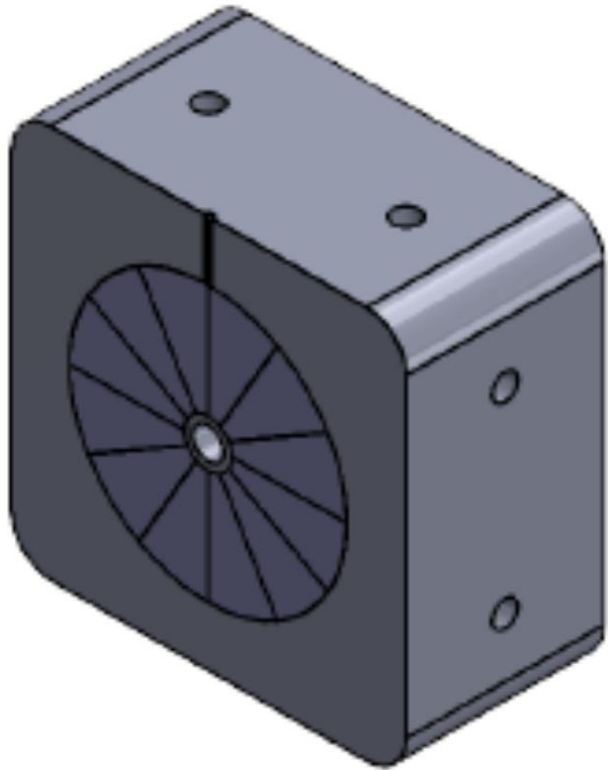

- Halbach quads from Magnet Sales Ltd
- Ni coated blocks for vacuum protection
- 2/3 months design 7 manufacture time

# Linear Optics Simulation

$$\phi = \begin{pmatrix} x \\ x' \\ y \\ y' \\ z \\ \delta \end{pmatrix}$$

Trace Space Matrix

$$T_{drift} = \begin{pmatrix} 1 & l & 0 & 0 & 0 & 0 \\ 0 & 1 & 0 & 0 & 0 & 0 \\ 0 & 0 & 1 & l & 0 & 0 \\ 0 & 0 & 0 & 1 & 0 & 0 \\ 0 & 0 & 0 & 0 & 1 & \frac{1}{\beta_0^2 \gamma_0^2} \\ 0 & 0 & 0 & 0 & 0 & 1 \end{pmatrix}$$

Drift Matrix

# Linear Optics Simulation

$$T_{Fquad} = \begin{pmatrix} \cos(\sqrt{k_q \cdot l_q}) & \frac{\sin(\sqrt{k_q \cdot l_q})}{\sqrt{k_q}} & 0 & 0 & 0 & 0 \\ -\sqrt{k_q} \sin(\sqrt{k_q \cdot l_q}) & \cos(\sqrt{k_q \cdot l_q}) & 0 & 0 & 0 & 0 \\ 0 & 0 & \cosh(\sqrt{k_q \cdot l_q}) & \frac{\sinh(\sqrt{k_q \cdot l_q})}{\sqrt{k_q}} & 0 & 0 \\ 0 & 0 & \sqrt{k_q} \sinh(\sqrt{k_q \cdot l_q}) & \cosh(\sqrt{k_q \cdot l_q}) & 0 & 0 \\ 0 & 0 & 0 & 0 & 1 & \frac{1}{\beta_0^2 \gamma_0^2} \\ 0 & 0 & 0 & 0 & 0 & 1 \end{pmatrix}$$

Focusing Quadrupole Matrix

# Linear Optics Simulation

$$T_{Dquad} = \begin{pmatrix} \cosh(\sqrt{k_q \cdot l_q}) & \frac{\sinh(\sqrt{k_q \cdot l_q})}{\sqrt{k_q}} & 0 & 0 & 0 & 0 \\ \sqrt{k_q} \sinh(\sqrt{k_q \cdot l_q}) & \cosh(\sqrt{k_q \cdot l_q}) & 0 & 0 & 0 & 0 \\ 0 & 0 & \cos(\sqrt{k_q \cdot l_q}) & \frac{\sin(\sqrt{k_q \cdot l_q})}{\sqrt{k_q}} & 0 & 0 \\ 0 & 0 & -\sqrt{k_q} \sin(\sqrt{k_q \cdot l_q}) & \cos(\sqrt{k_q \cdot l_q}) & 0 & 0 \\ 0 & 0 & 0 & 0 & 1 & \frac{1}{\beta_0^2 \gamma_0^2} \\ 0 & 0 & 0 & 0 & 0 & 1 \end{pmatrix}$$

Defocusing Quadrupole Matrix

# Quadrupoles Tested

Quadrupole	Strength	Length	Aperture
Quad 1	130 T/m	25mm	20mm
Quad 2	130 T/m	18mm	20mm
Quad 3	130 T/m	13mm	20mm



25mm then 13mm Quad at 130 T/m

# Optimal Quad Set

1.8m

1m

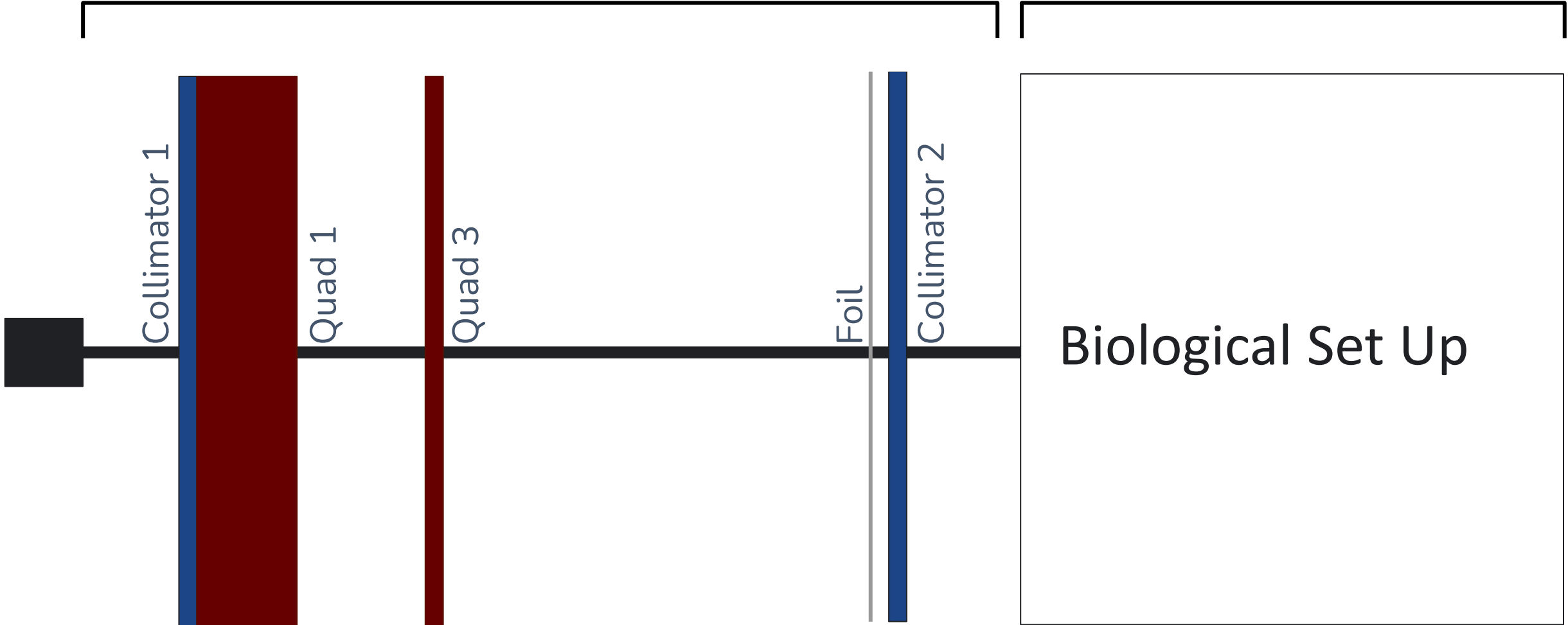

# Optimal Quad Set

<b>Energy (MeV)</b>	<b>Focusing quad position (m)</b>	<b>Drift between quads (m)</b>
5	0.138	0.145
7.5	0.170	0.193
10	0.194	0.243
12.5	0.218	0.279
15	0.239	0.325

# Optimal Quad Set-Example: 10MeV Visualiser

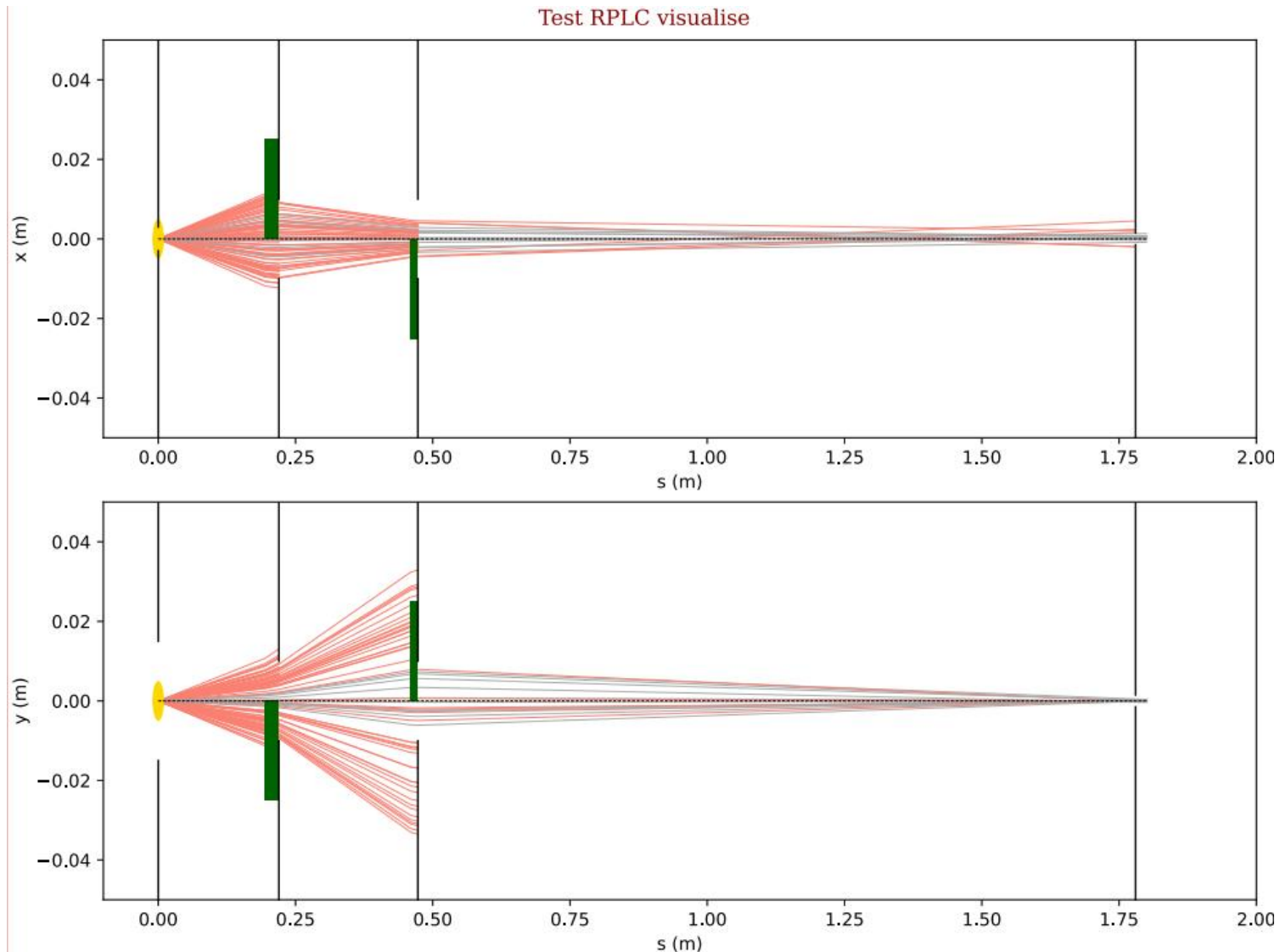

Key:

Blue- Particles that make it to the target

Red- Particles that don't make it to the target

# Optimal Quad Set- Example: 10MeV Beam shape at target

Beam geometrics

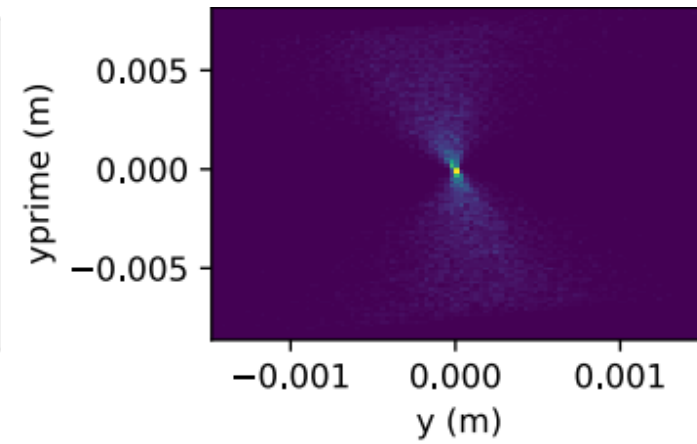
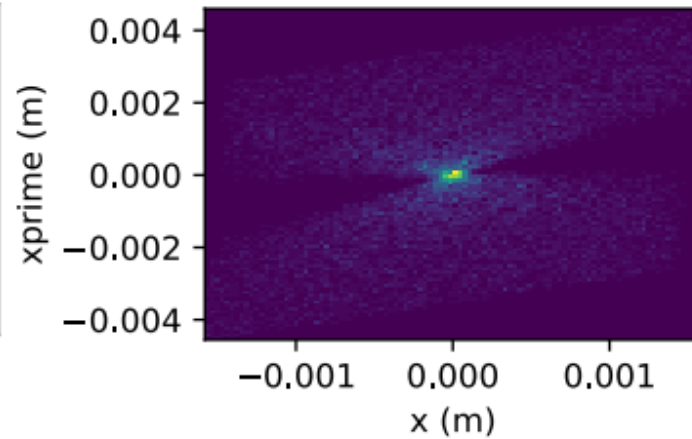
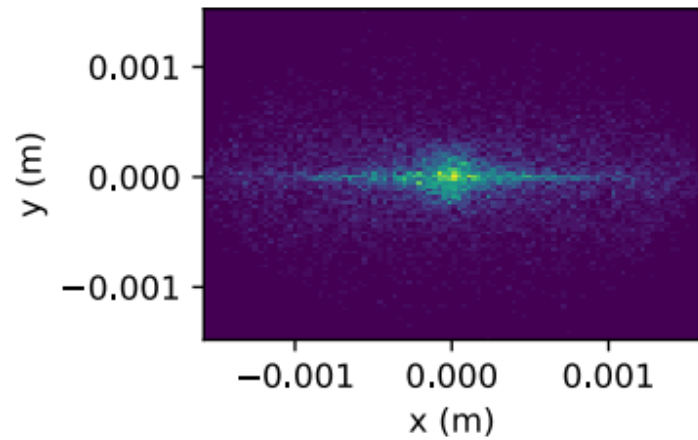

Beam distribution

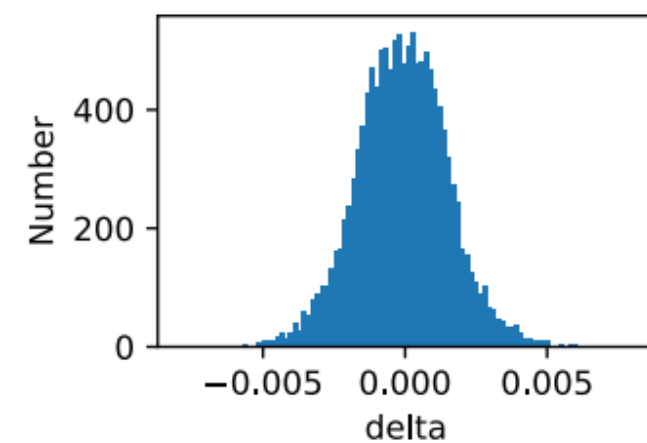
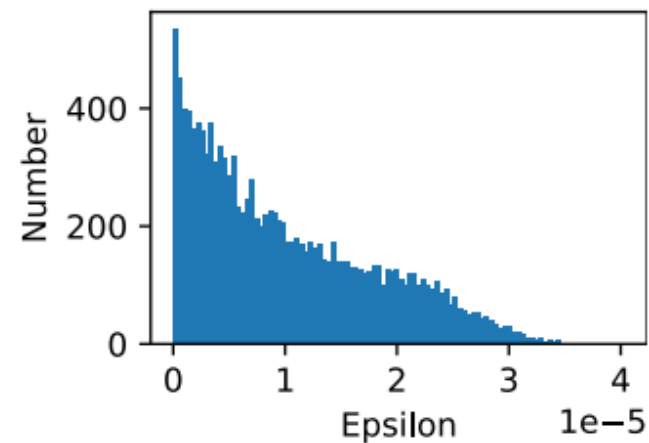
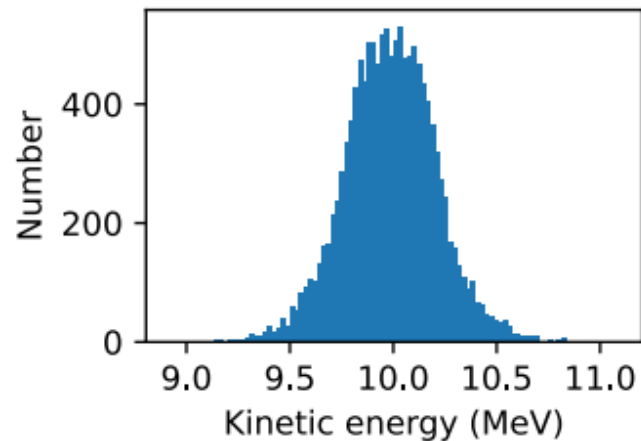

# PROPOSED TIMELINE

Deliverables for PoPLaR to keep the project on track for completion by October 2024.

